

PLAT OF BANYAN ISLE AT BALLENISLES

LYING IN SECTION 13, TOWNSHIP 42 SOUTH, RANGE 42 EAST,
 PALM BEACH COUNTY, FLORIDA, CITY OF PALM BEACH GARDENS
 MARCH 1995
 SHEET 2 OF 3

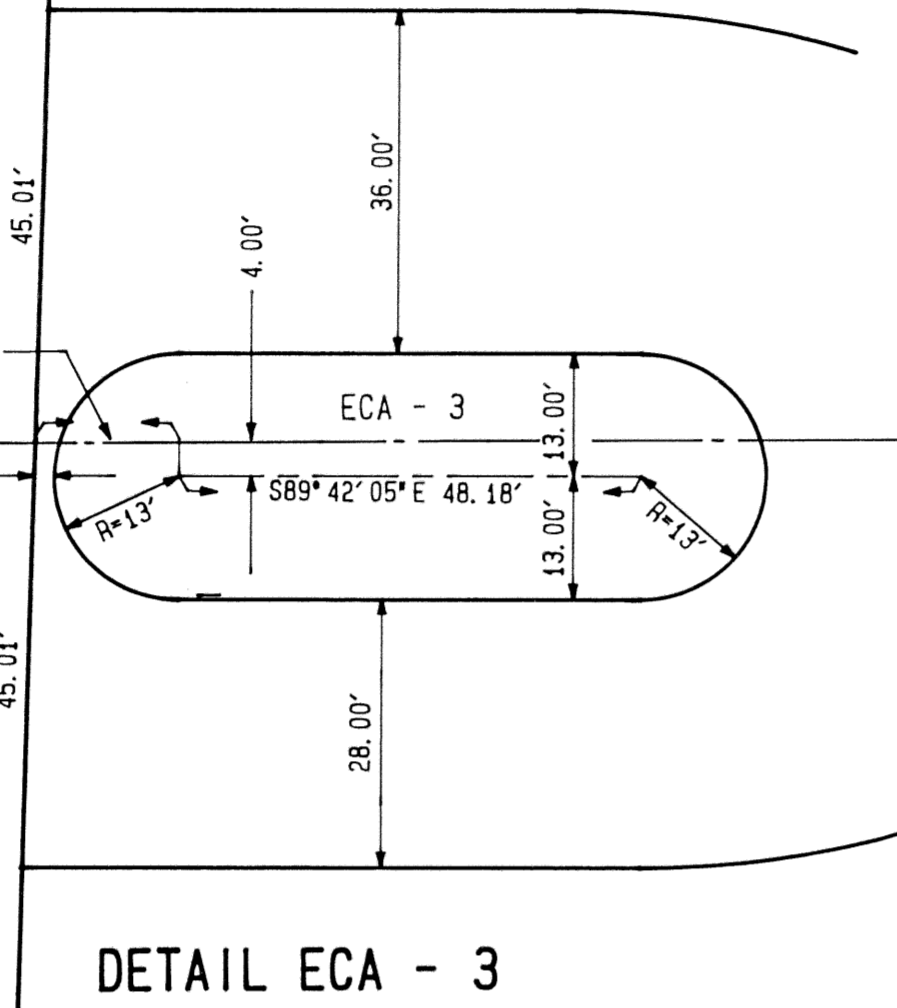
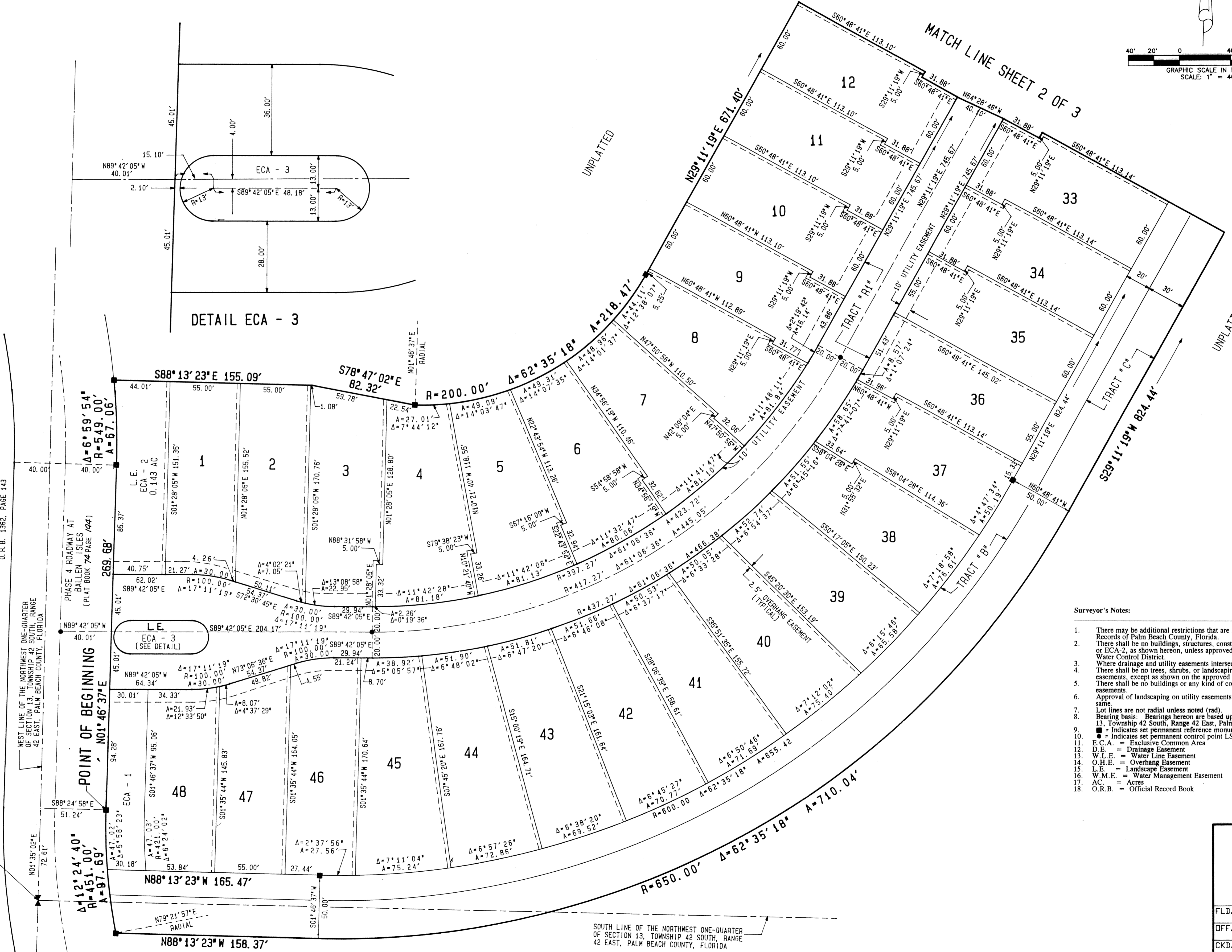
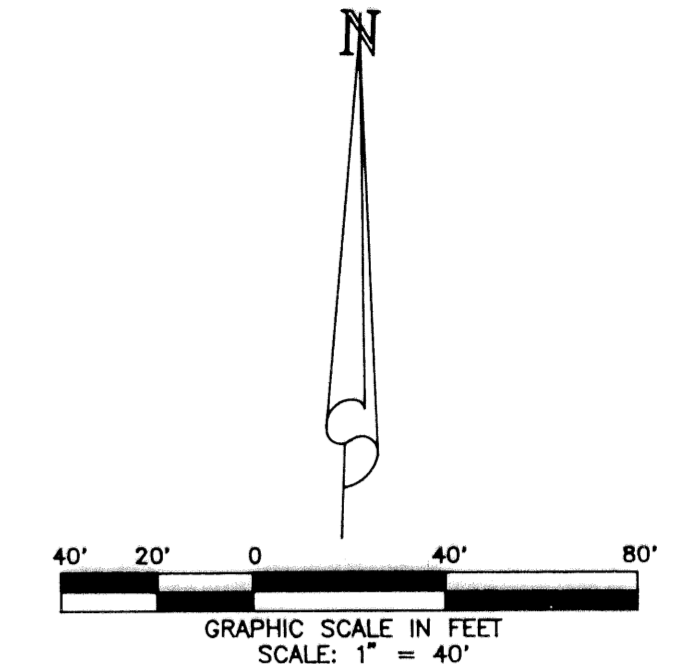

SUBDIVISION - Banyan Isle At
 Ballen Isles
 BOOK 75
 FLOOD ZONE -
 QUAD # -
 SE -
 PUD NAME -
 PAGE 66
 FLOOD MAP # -
 ZONING -
 ZIP CODE -
 C/P 66 gardens

POINT OF COMMENCEMENT
 SOUTHWEST CORNER OF THE NORTHWEST QUARTER
 OF SECTION 13, TOWNSHIP 42 SOUTH, RANGE
 42 EAST, PALM BEACH COUNTY, FLORIDA

- Surveyor's Notes:
- There may be additional restrictions that are not recorded on this plat that may be found in the Public Records of Palm Beach County, Florida.
 - There shall be no buildings, structures, construction of any kind, trees or shrubs placed on Tracts ECA-1 or ECA-2, as shown hereon, unless approved, in permit form, by the Northern Palm Beach County Water Control District.
 - Where drainage and utility easements intersect, drainage easements will take precedence.
 - There shall be no trees, shrubs, or landscaping placed on water and sewer easements or drainage easements, except as shown on the approved final development plan and/or landscape plan.
 - There shall be no buildings or any kind of construction placed on utility easements or drainage easements.
 - Approval of landscaping on utility easements shall be only with the approval of the utilities occupying same.
 - Lot lines are not radial unless noted (rad).
 - Bearing basis: Bearings hereon are based upon the West line of the northwest one-quarter of Section 13, Township 42 South, Range 42 East, Palm Beach County, Florida, being North 01° 35' 02" East.
 - = Indicates set permanent reference monument LS 3613.
 - = Indicates set permanent control point LS 3613.
 - E.C.A. = Exclusive Common Area
 - D.E. = Drainage Easement
 - W.L.E. = Water Line Easement
 - O.H.E. = Overlying Easement
 - L.E. = Landscape Easement
 - W.M.E. = Water Management Easement
 - AC = Acres
 - O.R.B. = Official Record Book

LIDBERG LAND SURVEYING INC.

675 West Indiantown Road, Suite 200,
 Jupiter, Florida 33458 TEL. 407-746-8454

FLD.	JOB	95-55	FB.	PG.
OFF.	E.A.D.	DATE	MARCH 1995	DWG.
CKD.	D.C.L.	REF.		SHEET 3 OF 3